

P-517 · P-527

Multi-Axis, PiezoStage Linear Slide with Parallel Metrology

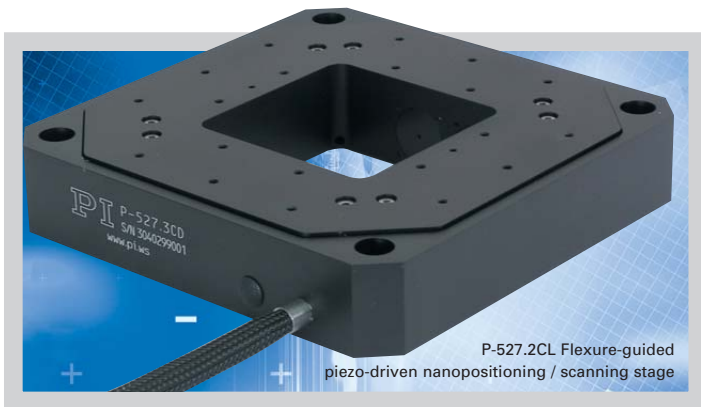

- XY θ_z , XYZ and XY Versions
- Precision Trajectory Control
- Parallel-Kinematics/Metrology for Enhanced Responsiveness / Multi-Axis Precision
- Travel Ranges to 200 μm
- Clear Aperture to 66 x 66 mm
- PICMA® High-Performance Piezo Drives

part of the stage. They detect errors contributed by all components in the drive train—from the actuator through the flexures to the platform. This results in higher motion linearity, long-term stability, phase fidelity, and—because external disturbances are seen by the sensor immediately—a stiffer, faster-responding servo-loop. See p. 2-4 *ff.* and p. 5-2 *ff.* for more information.

Parallel kinematics means that all actuators act directly on the same moving platform leading to reduced size, inertia and the elimination of microfriction caused by moving cables. The advantages are enhanced dynamics, higher scanning rates, and better reproducibility.

With parallel metrology, all sensors measure the position of the same moving platform against the same stationary reference (the fixed frame).

Technical Data

Models	P-517.2CL	P-527.2CL
Active axes	X, Y	X, Y
Open-loop travel @ 0 to 100 V	100 x 100	200 x 200
Closed-loop travel	100 x 100	200 x 200
Integrated feedback sensor	2 x capacitive	2 x capacitive
* Closed- / open-loop resolution	1 / 0.3	2 / 0.5
Closed-loop linearity (typ.)	0.03	0.03
Full-range repeatability (typ.)	± 5	± 10
Stiffness	2	1
Push / pull force capacity (in operating direction)	200 / 30	200 / 30
Max. (\pm) normal load	50	50
Electrical capacitance	9 / axis	9 / axis
** Dynamic operating current coefficient (DOCC)	11.5 / axis	5.5 / axis
Unloaded resonant frequency	450	350
Resonant frequency @ 500 g load	250	190
Resonant frequency @ 2500 g load	140	110
Operating temperature range	-20 to 80	-20 to 80
*** Voltage connection	2 x VL	2 x VL
*** Sensor connection	4 x C	4 x C
Weight (with cables)	1400	1400
Body material	Al	Al
Recommended amplifier/controller (codes explained p. 2-17)	H, F, L, K	H, F, L, K

Application Examples

- Biotechnology
- Metrology
- Lithography
- Nanopositioning
- Scanning microscopy
- Disk-drive testing
- Optical trapping
- Laser technology

This means that—in contrast to serial metrology—all motion is inside the servo-loop, no matter which actuator may have caused it, resulting in superior multi-axis precision (Active Trajectory Control).

Dynamic Digital Control for Best Scanning Linearity

Use our new digital control electronics with DDL (Dynamic Digital Linearization) to increase linearity and effective

Ordering Information

P-517.2CL

XY Piezo Nanopositioning Stage, 100 x 100 μm , Parallel Metrology, LEMO Connectors

P-527.2CL

XY Piezo Nanopositioning Stage, 200 x 200 μm , Parallel Metrology, LEMO Connectors

P-517.3CL / P-517.3CD *

XYZ Piezo Nanopositioning Stage, 100 x 100 x 20 μm , Parallel Metrology

P-527.3CL / P-527.3CD *

XYZ Piezo Nanopositioning Stage, 200 x 200 x 20 μm , Parallel Metrology

P-517.RCD

X, Y, θ_z Piezo Nanopositioning Stage, 100 x 100 μm , 2 mrad, Parallel Metrology, Sub-D

P-527.RCD

X, Y, θ_z Piezo Nanopositioning Stage, 200 x 200 μm , 4 mrad, Parallel Metrology, Sub-D

* .3CL with LEMO Connectors
.3CD with Sub-D Connectors

P-517 and P-527 single-module, multi-axis piezo-nanopositioning stages are available in XY θ_z , XY and XYZ configurations featuring linear travel ranges to 200 x 200 x 20 μm and rotation ranges to 4 mrad. The 66 x 66 mm clear aperture is ideal for transmitted-light applications. Z/tip/tilt versions in the same form factor are also offered (see the P-528, p. 2-52).

Higher Precision Through Parallel Kinematics/Metrology

P-500 series piezo stages feature a parallel-kinematics design with direct-measuring, non-contact capacitive position sensors (parallel, direct metrology). PI capacitive sensors are absolute-measuring devices that boast very high bandwidth and exhibit no periodic errors.

Unlike conventional sensors, capacitive sensors measure the actual distance between the fixed frame and the moving

bandwidth by up to 1000-fold (see p. 6-16).

Working Principle / Reliability

P-500 nanopositioning stages are equipped with the award winning PICMA® piezo drives, integrated into a sophisticated, single-module, parallel-kinematics, flexure guiding system. The flexures are FEA modeled for zero stiction, zero friction and exceptional guiding precision. The ceramic-encapsulated PICMA® drives are more robust than conventional piezo actuators, featuring superior lifetime and performance in both dynamic and static applications.

Because guidance, actuators and sensors are all frictionless and maintenance-free, these nanopositioning systems achieve outstanding levels of reliability.

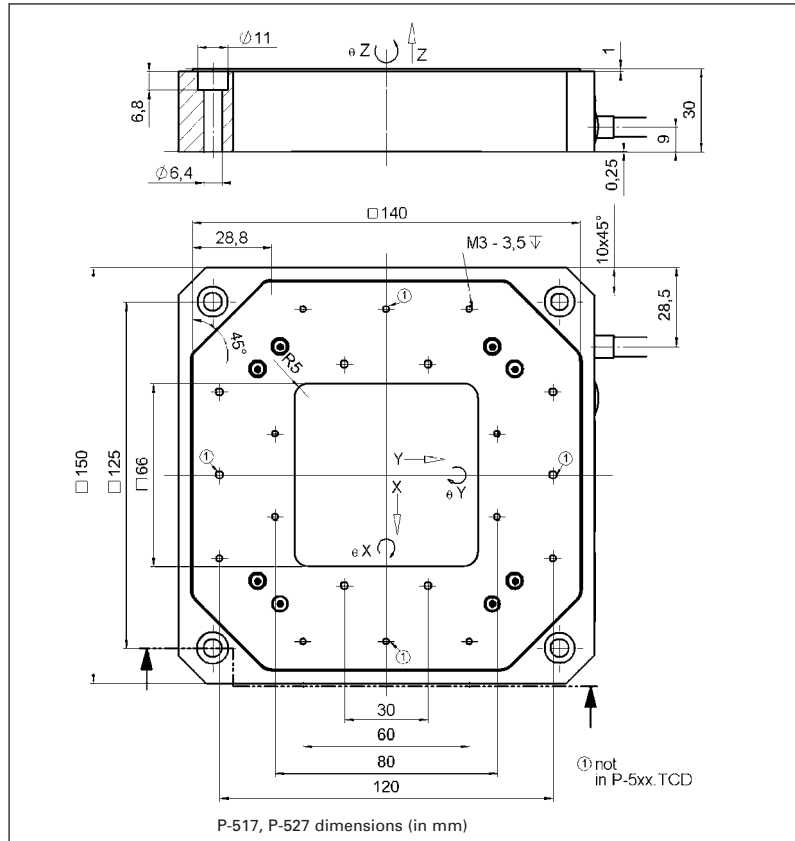

P-517, P-527 dimensions (in mm)

P-517.3CL/ P-517.3CD ****	P-527.3CL/ P-527.3CD ****	P-517.RCD	P-527.RCD	Units	Notes see p. 2-84
X, Y, Z	X, Y, Z	X, Y, θ_z	X, Y, θ_z		
100 x 100 x 20	200 x 200 x 20	100 ±1 mrad	200 ±2 mrad	µm ±20%	A2
100 x 100 x 20	200 x 200 x 20	100 ±1 mrad	200 ±2 mrad	µm	A5
3 x capacitive	3 x capacitive	3 x capacitive	3 x capacitive		B
X, Y: 1/0.3; Z: 0.1/0.1 0.03	X, Y: 2/0.5; Z: 0.1/0.1 0.03	X,Y: 1/0.3; θ_z : 0.3 /0.1 µrad 0.03	X, Y: 2/0.5; θ_z : 0.3/0.1 µrad 0.03	nm %	C1
X, Y: ±5; Z: ±1	X, Y: ±10; Z: ±1	X, Y: ±5; θ_z : ±0.5 µrad	X, Y: ±10; θ_z : ±1.0µrad	nm	C3
X, Y: 2; Z: 15	X, Y: 1; Z: 15	2	1	N/µm ±20%	D1
200 / 30; Z: 50 / 30	200 / 30; Z: 50 / 30	200 / 30	200 / 30	N	D3
50	50	50	50	N	D4
X, Y: 9; Z: 6	X, Y: 9; Z: 6	X, Y: 9	X, Y: 9	µF ±20%	F1
X, Y: 11.5; :Z: 62	X, Y: 5.5; :Z: 62	X, Y: 11.5	X, Y: 5.5	µA/(Hz x µm)	F2
450; Z: 1100	350; Z: 1100	X, Y: 450; θ_z : 400	X, Y: 350; θ_z : 300	Hz ±20%	G2
X, Y: 250	X, Y: 190	X, Y 250	X, Y: 190	Hz ±20%	G3
X, Y: 140	X, Y: 110	X, Y 140	X, Y: 110	Hz ±20%	G3
-20 to 80	-20 to 80	-20 to 80	-20 to 80	°C	H2
3 x VL ****	3 x VL ****	D	D		J1
6 x C ****	6 x C ****	D	D		J2
1450	1450	1400	1400	g ±5%	
Al	Al	Al	Al		L
H, F, L	H, F, L	K	K		

- Piezo Actuators
- Nanopositioning & Scanning Systems**
- Active Optics / Steering Mirrors
- Tutorial: Piezo-electrics in Positioning
- Capacitive Position Sensors
- Piezo Drivers & Nanopositioning Controllers
- Hexapods / Micropositioning
- Photonics Alignment Solutions
- Motion Controllers
- Ceramic Linear Motors & Stages
- Index

* For calibration information see p. 2-8. Resolution of PI piezo nanopositioners is not limited by friction or stiction. The value given is noise equivalent motion with E-710, E-503.

** Dynamic Operating Current Coefficient of linear axes is in µA per Hz and µm. Example P-527.2xx: Sinusoidal scan of 30 µm at 10 Hz requires approximately 1.8 mA drive current.

*** Cable length: 1.5 m. P-5x7.xCD with one sub-D special connector for sensor and operating voltage. P-5x7.xCL with LEMMO connectors.

**** P-5x7.3CD with one sub-D special connector for sensor and operating voltage.